



# MAVERICK<sup>®</sup>

## Technician-Focused Tyre Changer



Reach new levels in your shop.



Fully variable controls



10-34 inch rim diameters



Hydraulic speed and accuracy



Optional lighted lower roller



TCMPRO shown

Three models to suit every need

# "MAVERICK HAS YOUR BACK"

**MADE IN USA**  
USING THE FINEST US & GLOBAL MATERIALS



### TCMW

features a compact wheel lift that is perfect for extreme wide wheels and can double as a tyre lift when servicing heavy assemblies such as 19.5s.



### TCM (base model)

The Maverick® technician-focused tyre changing machine designed and built in the USA provides fully variable hydraulic control and unique features for a safe and easy tyre changing process.

All TCM models available in red or black.



### TCMPRO

features an ergonomic "pick and place" wheel lift for complete control of heavy assemblies. A lighted lower roller makes bead breaking and lubrication easier.

## GO "PRO" FOR MAXIMUM BENEFITS

### TCMPRO INCLUDES ERGONOMIC "PICK AND PLACE" WHEEL LIFT

- ✓ 175 lbs. capacity, including 19.5s

- ✓ Holds position while elevated
- ✓ Reversible pedal configuration
- ✓ Automatic lowering



Lifts and tilts heavy assembly in one smooth motion

### TCMPRO INCLUDES A LIGHTED LOWER ROLLER

- ✓ Significantly improves lower roller visibility for easier bottom bead breaking and lubrication
- ✓ Shielded design prevents glare and damage from debris
- ✓ Activates automatically with lower roller operation
- ✓ Automatic timer shutoff when lower roller is inactive (customizable by user)



Light mounted to back of spindle



Change the way you change tyres

# CONTROL WHERE YOU EXPECT

The Hunter Maverick® tyre changing machine combines the convenience of hydraulic movement with the speed and responsiveness of manual operation.



## EXCLUSIVE

### Groundbreaking responsive controls

- ✓ Fine control or fast on-demand
- ✓ Hydraulic precision easier than air controls
- ✓ Ergonomic for all-day use
- ✓ Excellent tactile feedback – one-finger control for all functions

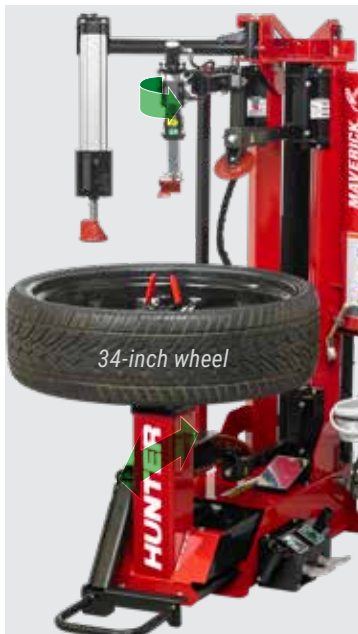
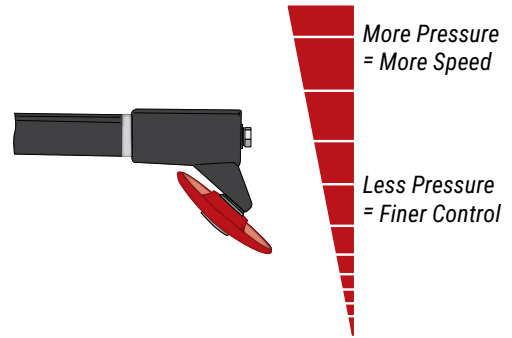

34-inch wheel



Tool head simultaneously adjusts as base adjusts for wheel size.

## PATENT PENDING

### Articulating leverless system

- ✓ All tools automatically sync to rim diameter
- ✓ Rim diameter retained for maximum efficiency of wheel sets

## EXCLUSIVE

### Intelligent safety and productivity

- ✓ Monitors roller and hook positions
- ✓ Logic automatically “homes” rollers, head, and wheel lift for hands-free productivity
- ✓ Prevents unintended wheel contact
- ✓ Smart software: customize travel and rotate speeds, ramp rate, and more

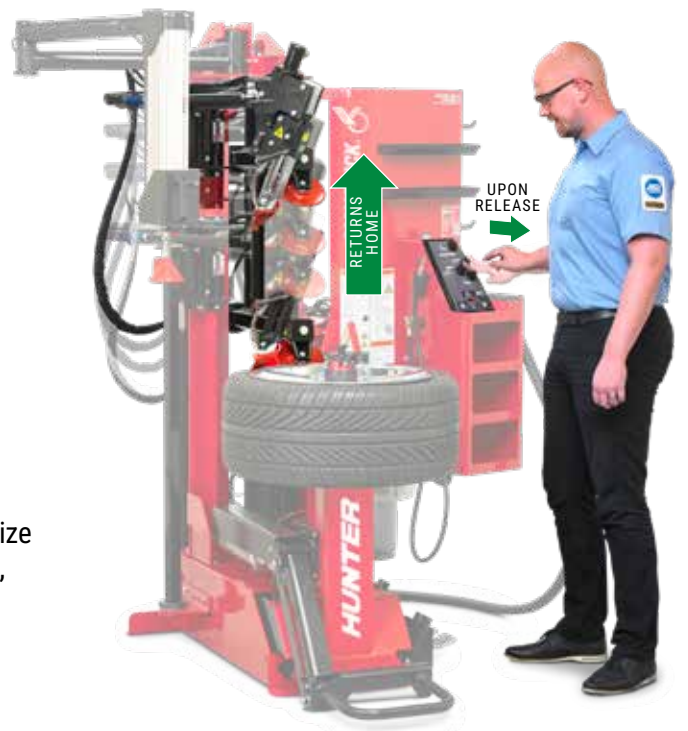

TCMW shown with compact wheel lift

Designed with technician feedback

# USABILITY YOU NEED

The Hunter Maverick® tyre changing machine has forward-thinking features designed to give technicians complete control.

## EXCLUSIVE

### A InflationStation™ boosts productivity

- ✓ InflationStation™ automatically fills tyre to desired pressure – inflates at the press of a button
- ✓ Operator stands back or even walks away from inflation
- ✓ 33% faster than standard inflation systems



Blast inflation directs large blast of air for tough bead seating.



## EXCLUSIVE

### B SmartSet® leverless head

- ✓ Demounting hook deploys to catch and lift bead
- ✓ No risk of lever damage to operator or rim
- ✓ Mount head works with clad, raised spoke, and other unique wheel designs



### D Optional pick and place wheel lift

- ✓ Lifts and positions the heaviest tyres with ease
- ✓ Holds position while elevated
- ✓ Auto lowering saves time and prevents damage

PATENT PENDING

## **C** RollerLock® clamp

- ✓ Ball bearing threads clamp quickly and tightly
- ✓ Lever handles multiply clamping force
- ✓ Smooth shaft reduces center bore damage risk



## **E** Variable speed rotation

- ✓ 0-17 RPM for fast cycle times
- ✓ Fully variable reverse rotation for maximum control

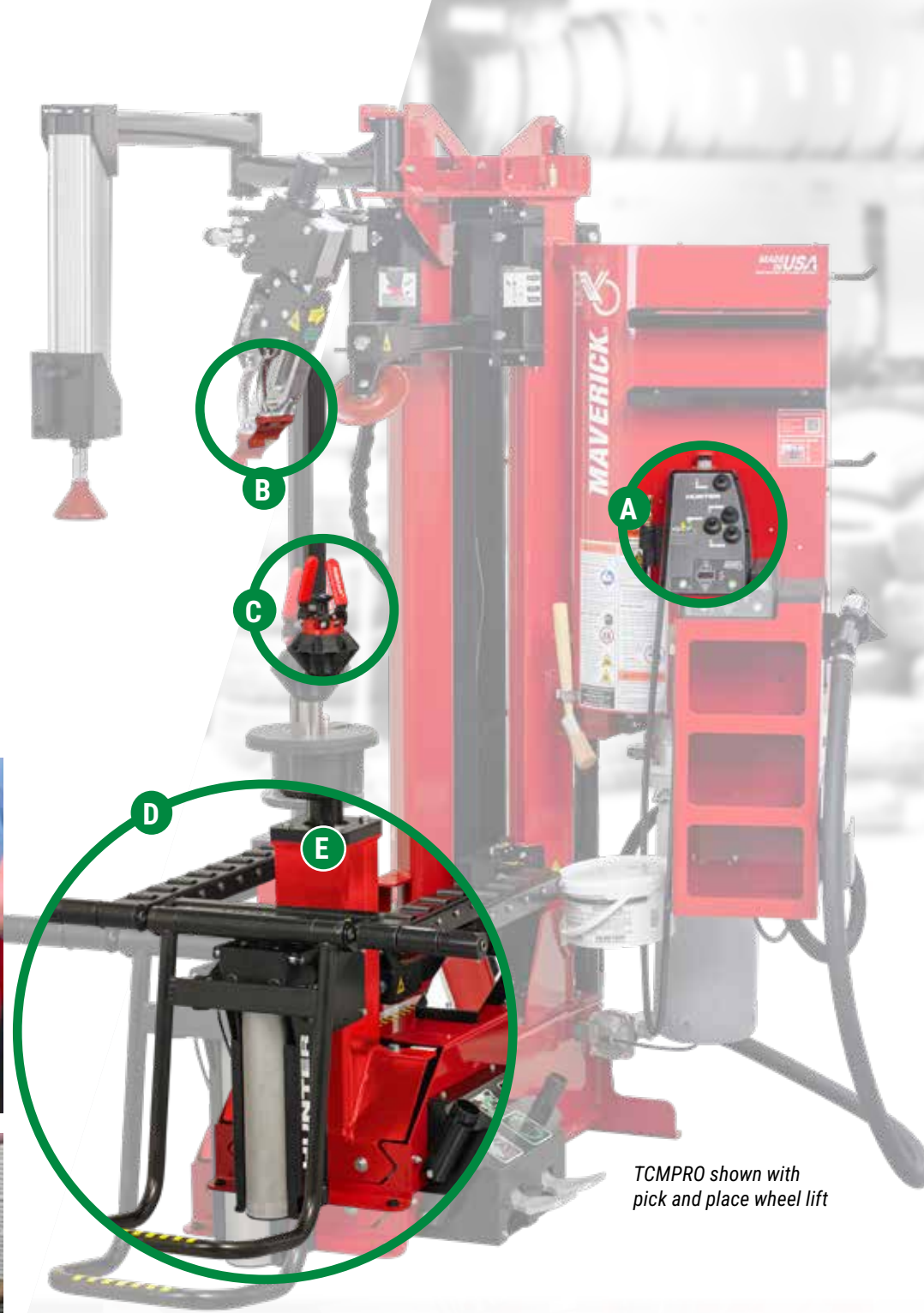

TCMPRO shown with pick and place wheel lift

## Self-contained hydraulic operation

- ✓ Each tool can be moved quickly, slowly, or held as needed
- ✓ No erratic movement when loaded and unloaded
- ✓ Compressed air contamination not a factor



# DOUBLE-DUTY BEAD PRESS

The Hunter Maverick® tyre changing machine's bead press arm is a powerful assistant for tough applications.

When used with Hunter's Road Force Elite®, the Maverick® quickly and easily helps eliminate vibration problems balancers alone can't fix.



## Powered bead press

- ✓ Simple joystick control
- ✓ Handles the toughest tyres



## Multi-functional

- ✓ Arm rotates with wheel
- ✓ Bead ledge allows pusher to be used as a lifting device also



## Match-mounting

Bead rollers allow spinning of the tyre on the rim, helping match-mount the stiffest point on the tyre to the low spot on the rim

# TYRE SERVICEABILITY

The Maverick® tyre changer provides a wide range of tyre serviceability due to its patent pending articulating leverless system, hydraulic operation, and other crafted features.



**HANDLING REVERSE WHEELS:** Center clamping is preferred for reverse wheels. Using a flange plate protects the front face of the wheel and eliminates the risk of slippage. Reverse wheels are also often high diameter, which are better serviced on a center-clamp, roller-based machine.



**ELECTRIC VEHICLE TYRE SERVICE:** EV tyres are often stiffer with a lower profile than internal combustion engine (ICE) vehicle tyres in order to handle the higher weight and torque while still offering low rolling resistance. These attributes coupled with their lightweight alloy wheel make them better suited for service with center-clamp, leverless machines.



**HANDLING 19.5" ASSEMBLIES:** (requires accessories) A leverless machine is preferred for 19.5s. Rim clamping is sometimes preferred, since they do not require clamping adaptors. A wheel lift is a back saver, too.

OEM STANDARD	Standard		✓	
	Truck/SUV		✓	
	Low-Profile		✓	
OEM RUN-FLATS	Car		✓	
	Van/SUV		✓	
	High-Performance		✓	
AFTERMARKET	Aftermarket Single Piece		✓	
	Aftermarket Mudder		✓	
	Aftermarket 2 & 3 Piece		✓	
THICK-BEAD	Requires Accessories	Skid Steer		✓
		19.5 in.		✓

The Maverick® tyre changer is proudly made in the USA using the highest-quality materials sourced domestically and internationally.

**MADE  
IN USA** ★  
USING THE FINEST US & GLOBAL MATERIALS



### **Optional compact wheel lift – 20-4170-1**

- ✓ Lifts the heaviest assemblies with ease, including 19.5s
- ✓ Auto lowering saves time and prevents damage
- ✓ Perfect for extreme wide wheels
- ✓ Can double as a lift for heavy tyres while rim is clamped in place

# MAVERICK® SPECIFICATIONS

<b>Power Requirements</b>	<b>TCM:</b> 220 V, 1 Ph, 60 Hz <b>TCME-215:</b> 220 V, 1 Ph, 50 Hz <b>TCME-435:</b> 400 V, 3 Ph, 50 Hz
<b>Air Supply Requirements</b>	8.6 ± 1.7 bar (125 ± 25 psi)
<b>Mount / Demount Tool</b>	Polymer head w/ Leverless
<b>Clamping Type</b>	Center w/RollerLock
<b>Bead Loosening Type</b>	Upper / Lower Roller
<b>Match Mounting Capable</b>	Yes
<b>Rim Diameter Range</b>	10 in. – 34 in. (254 mm – 864mm)
<b>Maximum Tyre Diameter</b>	1270 mm (50 in.)
<b>Maximum Wheel Width</b>	483 mm (19 in.)
<b>Drive</b>	Variable up to 17 rpm Clockwise/Counter Clockwise; Torque: 949 Nm (700 ft-lbs)
<b>Shipping Weight</b>	557-603 kg (1230-1330 lbs)

	Width	Height	Depth	Depth	Weight
<b>TCM</b> (standard)	1346 mm 53 in	1956 mm 77 in	1168 mm 46 in	1448 mm 57 in	483 kg 1065 lbs
<b>TCMW</b> (with compact lift)			<b>Depth</b>	<b>Depth</b>	<b>Weight</b>
			1524 mm 60 in	1803 mm 71 in	514 kg 1132 lbs
<b>TCMPRO</b> (with pick and place lift and light)			<b>Depth</b>	<b>Depth</b>	<b>Weight</b>
			1778 mm 70 in	2057 mm 81 in	520 kg 1145 lbs

(see CS08034-00 for detailed specifications)

## WDK Accessories Kit – 20-3985-1



Change the way you change tyres.

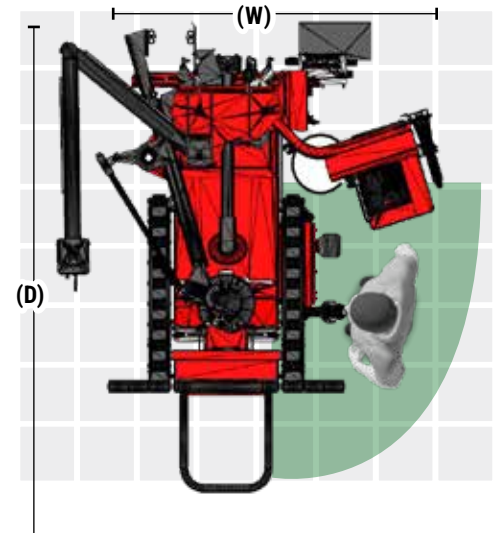

Machine can be placed right against a wall for maximum space efficiency.

## Your Hunter distributor is ready to help

- ✂ Receive same- or next-day service
- 📞 Get a free quote or on-site demo
- 📖 Register for training courses
- 🗨 General information and questions



Contact your local distributor

[hunter.com/contact](https://hunter.com/contact)



Because of continuing technological advances, specifications, models and options are subject to change without notice.

Maverick, SmartSet, Road Force Elite, and HunterNet are registered trademarks of Hunter Engineering Company. InflationStation is a trademark of Hunter Engineering Company.

0925DH

Copyright © 2025, Hunter Engineering Company

**HUNTER**  
Engineering Company

[www.hunter.com](https://www.hunter.com)

11250 Hunter Drive, Bridgeton, MO 63044, USA  
Tel: 1-314-731-3020, Fax: 1-314-731-0132  
Email: [international@hunter.com](mailto:international@hunter.com)

Form CB08056-05, 09/25

Supersedes form CB08056-05, 12/24