

GEDORE

TOOLS FOR LIFE

Timing Chain Tool Kit, Mercedes



KL-0340-22 K

KL-0340-23 K

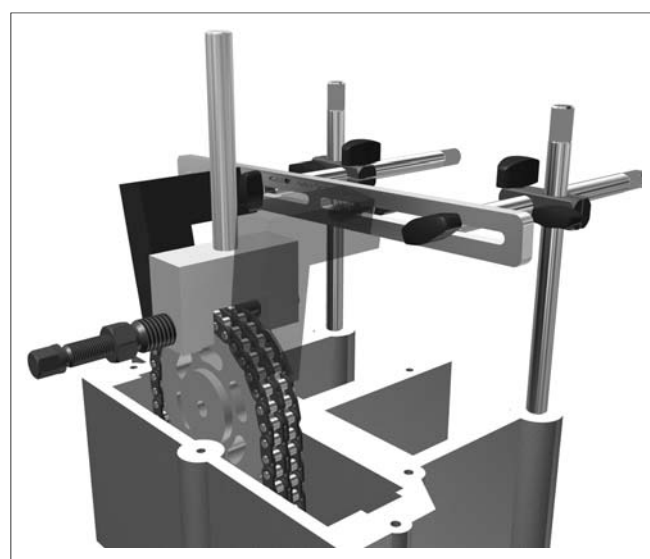

0340-22Ke150419.docx

GEDORE Automotive GmbH

Breslauer Straße 41
78166 Donaueschingen

Postfach 1329
78154 Donaueschingen - GERMANY

Phone: +49 (0) 771 / 8 32 23-0
Fax: +49 (0) 771 / 8 32 23-90

Email: info@gedore-automotive.com
Internet: www.gedore-automotive.com

KL-0340-22 K

For Simplex and Duplex Timing Chains



KL-0340-23 K

For Simplex Timing Chains



Scope of Delivery:

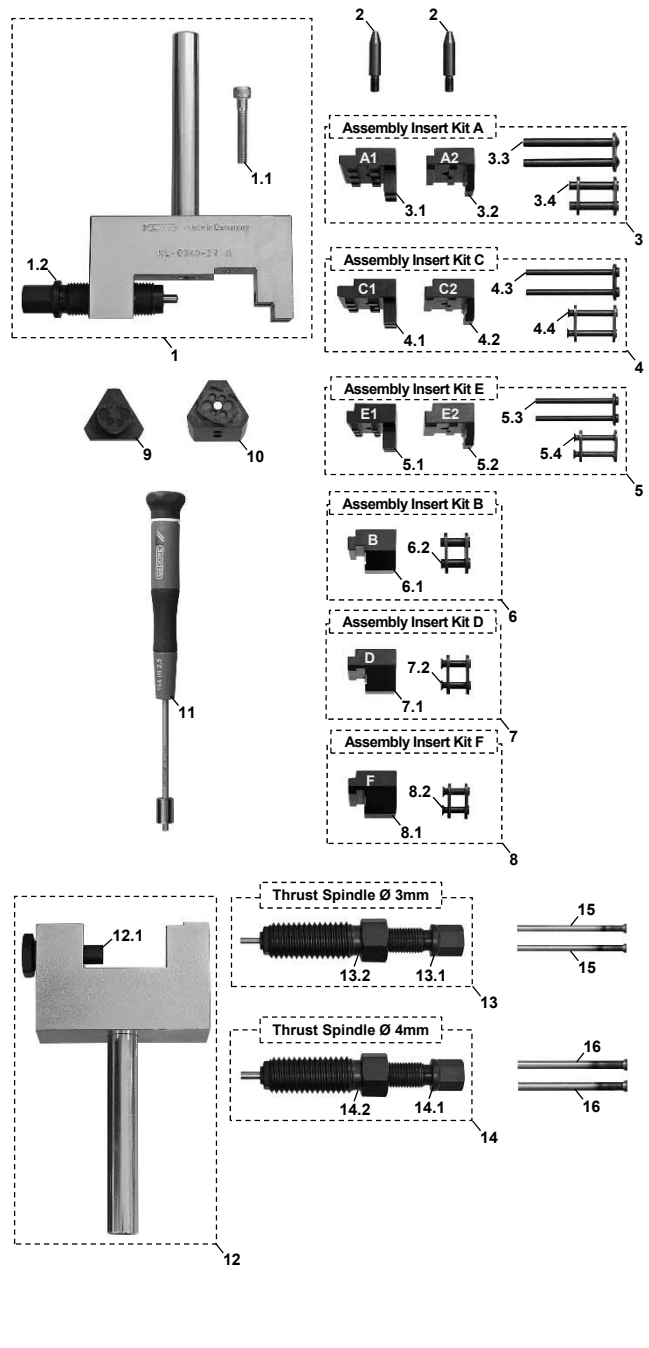

KL-0340-22 K - Timing Chain Master Tool Kit, Mercedes

Suitable for use on Mercedes M102, M112, M113, M271, M272, OM628, OM642, OM651, OM668 and Opel/Vauxhall petrol as well as Diesel engines both with Simplex or Duplex timing chains.

As fitted to: Mercedes A-Class (W168), B-Class (W246), C-Class (W202, W203, W204), E-Class (W207, W210, W211, W212), G-Class (W460, W461, W463), R-Class (W251), S-Class (W220, W221), CLS (W218, W219), CLK (W208, W209), SL (W129, W230), SLK (W170, W171, W172), ML (W163, W164, W166), GL (X164), GLK (X204), Sprinter (W906), Vaneo (W414), Viano (W639), Vito (W639), 190 (W201), 200-300 (W123), 200-500/E (W124).

Field of Application

The timing chain tool kit allows for the quick and neat separation, pulling in and riveting of simplex timing chains as well as of duplex timing chains with the centre plate pressed-on as found in Mercedes engines.

KL-0340-23 K - Timing Chain Base Tool Kit, Mercedes

Like KL-0340-22 K, but only applicable to Mercedes M271, OM651 and Opel/Vauxhall petrol as well as Diesel engines featuring a Simplex timing chain.

Scope of Delivery: KL-0340-22 K / KL-0340-23 K

Pos.	Part No.	Description	Qty.	Kit	
				KL-0340-22 K	KL-0340-23 K
1	KL-0340-211	Riveting Tool (base tool)	1	•	•
1.1	KL-0340-0005	Hexagon Socket Screw, M5 x 30mm			
1.2	KL-0340-2113	Pressure Screw			
2	KL-0340-2203	Centring Pin, M5	2	•	•
3	KL-0340-221	Assembly Insert Kit A	1	•	
3.1	KL-0340-2121	Assembly Guide Rail A1			
3.2	KL-0340-2131 A	Guide Rail A2			
3.3	KL-0340-2123	Assembly Guide Link, Ø 4.4mm			
3.4	KL-0340-2215	Assembly Link, Ø 4.4mm			
4	KL-0340-223	Assembly Insert Kit C	1	•	
4.1	KL-0340-2231	Assembly Guide Rail C1			
4.2	KL-0340-2232	Guide Rail C2			
4.3	KL-0340-2233	Assembly Guide Link, Ø 3.2mm			
4.4	KL-0340-2235	Assembly Link, Ø 3.2mm			
5	KL-0340-225	Assembly Insert Kit E	1	•	
5.1	KL-0340-2251	Assembly Guide Rail E1			
5.2	KL-0340-2252	Guide Rail E2			
5.3	KL-0340-2253	Assembly Guide Link, Ø 3mm			
5.4	KL-0340-2255	Assembly Link, Ø 3mm			
6	KL-0340-222	Assembly Insert Kit B	1	•	•
6.1	KL-0340-2222	Guide Rail B			
6.2	KL-0340-2225	Assembly Link, Ø 4.4mm			
7	KL-0340-224	Assembly Insert Kit D	1	•	
7.1	KL-0340-0011 A	Guide Rail D			
7.2	KL-0340-2245	Assembly Link, Ø 3.2mm			
8	KL-0340-226	Assembly Insert Kit F	1	•	•
8.1	KL-0340-2262	Guide Rail F			
8.2	KL-0340-2265	Assembly Link, Ø 3mm			
9	KL-0340-2201	Multi Thrust Piece 1	1	•	•
10	KL-0340-2202	Multi Thrust Piece 2	1	•	•
11	KL-0340-2205	Screwdriver	1	•	•
12	KL-0340-201 A	Breaker Tool (base tool)	1	•	•
12.1	KL-0340-2013 A	Centring Sleeve			
13	KL-0340-204	Thrust Spindle, Ø 3mm	1	•	•
13.1	KL-0340-2023	Pressure Screw			
13.2	KL-0340-2021	Clamping Screw			
14	KL-0340-202	Thrust Spindle, Ø 4mm	1	•	•
14.1	KL-0340-2023	Pressure Screw			
14.2	KL-0340-2021	Clamping Screw			
15	KL-0340-205	Clipping Punch, Ø 3mm (2 units)	1	•	•
16	KL-0340-203	Clipping Punch, Ø 4mm (2 units)	1	•	•
-	KL-0340-2090	Plastic Storage Case	1	•	•

Application Table: Depending on the type of engine, determine the necessary tools as follows:







Engine Codes:		Breaking a timing chain:	Riveting a timing chain:						
		Thrust Spindle: 	Multi Thrust Piece 1: 	Multi Thrust Piece 2: 	Assembly Insert Kit:				
					Assembly Guide Rail: 	Guide Rail: 	Assembly Guide Link: 	Assembly Link: 	
Engines with Duplex timing chain 	Mercedes OM 611/OM 612 OM 613/OM 628 OM 642/OM 668 (a-9.45mm/Ø 4.45mm)	"14"	"9"	"10"	A	A1 "3.1"	A2 "3.2"	"3.3"	"3.4"
	Mercedes M 112/M 113 (a-9.45mm/Ø 3.28mm)	"13"	"9"	"10"	C	C1 "4.1"	C2 "4.2"	"4.3"	"4.4"
	Mercedes OM 272 (a-8mm/Ø 3.14mm)	"13"	"9"	"10"	E	E1 "5.1"	E2 "5.2"	"5.3"	"5.4"
Engines with Simplex timing chain 	Mercedes OM 651 (a-9.45mm/Ø 4.45mm)	"14"	-	"10"	B	-	B "6.1"	-	"6.2"
	Mercedes M 102 (a-9.45mm/Ø 3.28mm)	"13"	-	"10"	D	-	D "7.1"	-	"7.2"
	Mercedes OM 271 Smart/Opel/Vauxhall (a-8mm/Ø 3.14mm)	"13"	-	"10"	F	-	F "8.1"	-	"8.2"

Fig. 1: Preparing the Breaker Tool.

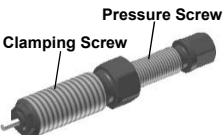

Warnings and Notes

- DO NOT operate the tool by means of an impact wrench.
- Before use, lubricate spindle with molybdenum disulphide paste **KL-0014-0030**.
- Before putting the tool into operation, carry out a visual check to ensure that it is not damaged.
- Always refer to the vehicle manufacturer's data and instructions as only these apply to all work that is carried out on the vehicle.
- All specific vehicle data stated herein are supplied under reserve and without commitment.

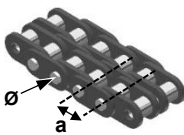
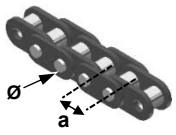
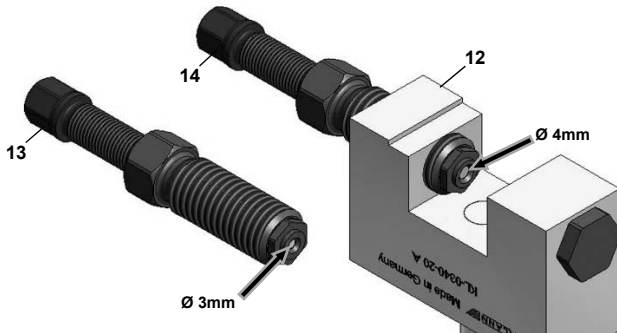
Preparing the Breaker Tool.

1. Depending on the type of engine, screw either thrust spindle "13" or "14" (see application table) into base breaker tool "12". (Fig. 1)

Preparing the Riveting Tool.

1. Depending on the type of engine, get riveting tool "1" and all the necessary tools for riveting (see application table) ready for use.

Preparing the Vehicle.

1. Remove components/parts as may be necessary (valve cover etc.).
2. Make sure falling parts and dirt are prevented from entering the timing chain case.

Fig. 2: Installing the mounting device (accessory).

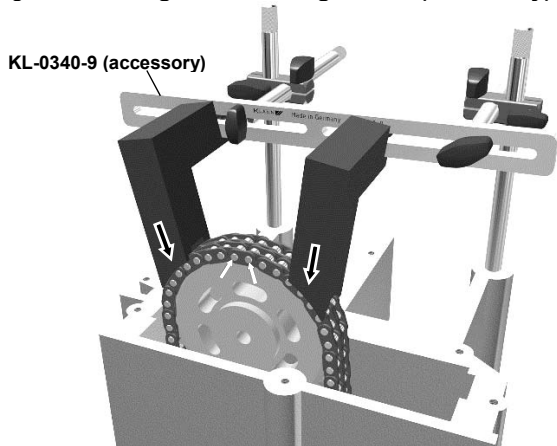

Fig. 3: Positioning the breaker tool.

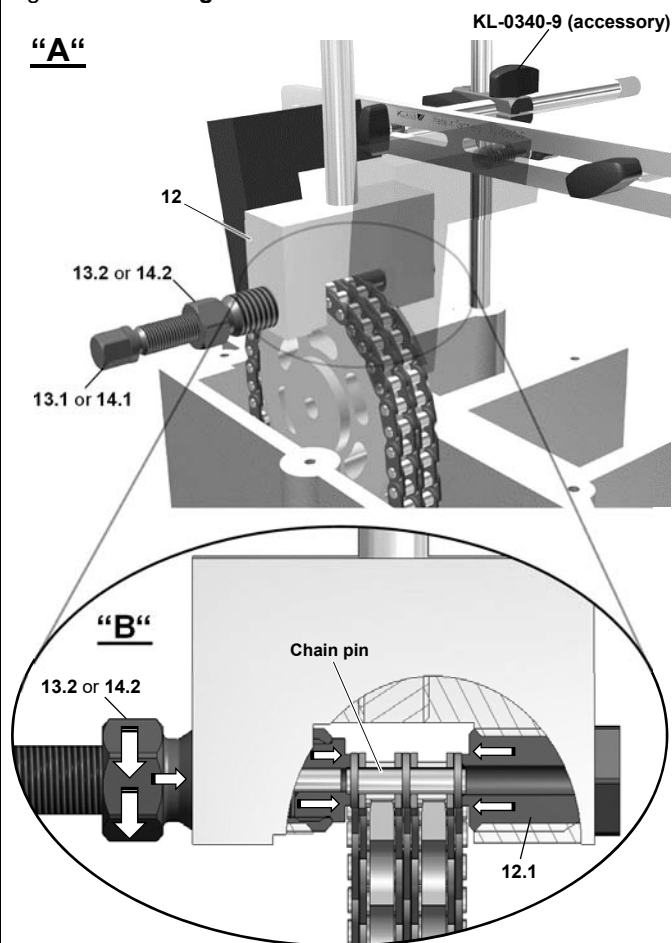
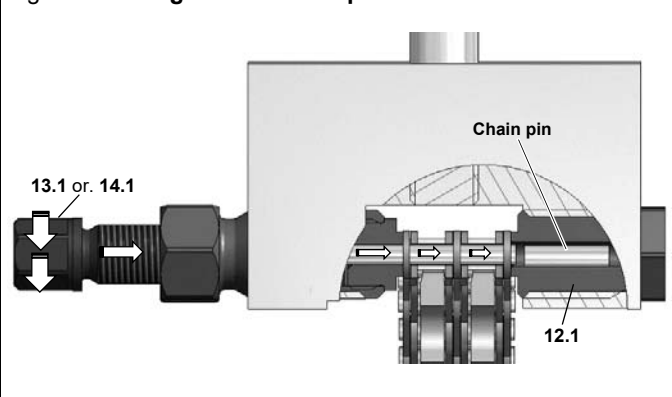

Fig. 4: Pressing out the chain pin.



Example of Use:

Separating the Timing Chain

Note: The following instructions describe the procedure of separating a Duplex timing chain. The separation of Simplex timing chains is carried out following the same principle.

1. Install the **KL-0340-9** universal mounting device (**accessory**) as shown in the example in **Fig. 2**.

The special design of the **KL-0340-9** universal mounting device (**accessory**) prevents skipping a tooth during assembly thus allowing the professional installation of the new timing chain to be performed quickly and without any trouble by one single mechanic.

2. Release the automatic chain tensioner.

3. Position the suitably prepared breaker tool "12" over timing chain as shown in **Fig. 3 A**.

Be sure that pressure screw "13.1" or "14.1" as well as clamping screw "13.2" or "14.2" have been completely turned back.

4. Manually screw clamping screw "13.2" or "14.2" towards timing chain until screw "13.2" or "14.2" and centring sleeve "12.1" rest neatly and plane against the relative chain link. (**Fig. 3 B**)

5. Press out chain pin by screwing in pressure screw "13.1" or "14.1". (**Fig. 4**)

After having turned back pressure screw "13.1" or "14.1", remove breaker tool "12" from timing chain.

Note:

Make sure that the pressed-out chain pin is prevented from falling into the engine.

Always be sure to remove the pressed-out chain pin from the centring sleeve "12.1" in breaker tool "12". Failure to do so would block the next pressing out operation.

When working on Duplex timing chains, **always make sure** that the centre link plate cannot fall into the engine once the chain pin has been pressed out.

6. The second chain pin is pressed out following the same principle. For this, repeat working steps 3-5.

Fig. 5: Pulling in a new timing chain.

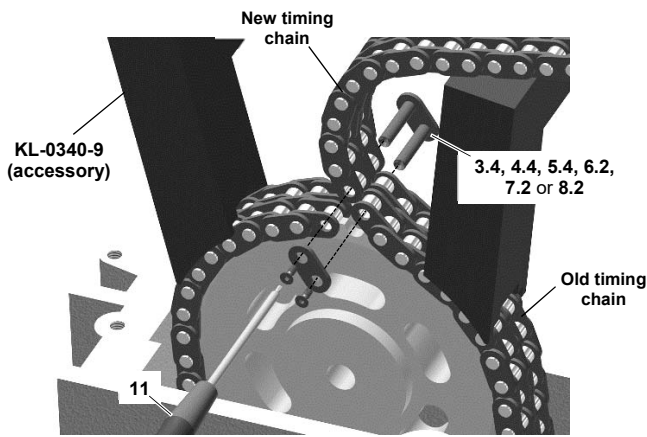

Fig. 6: Connecting the new timing chain.

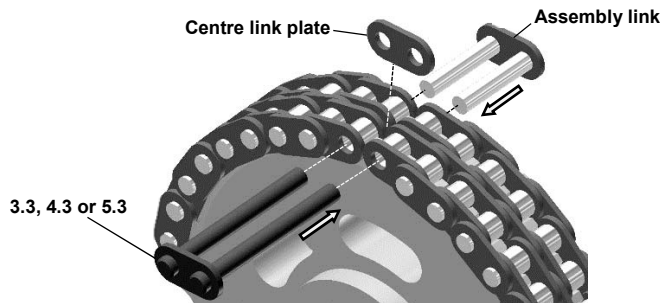
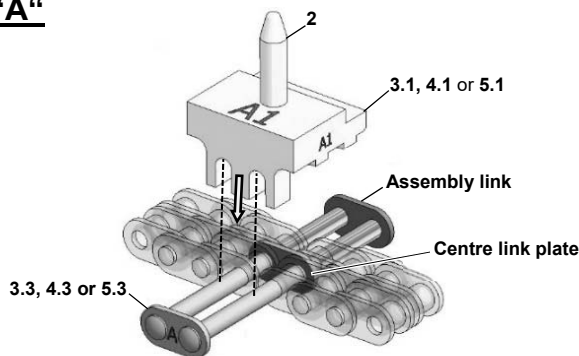
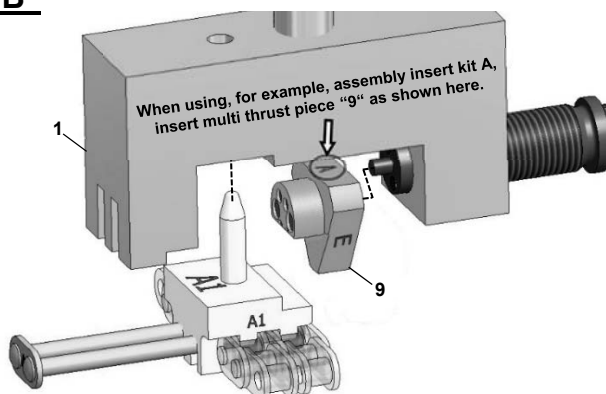

Fig. 7: Positioning the assembly guide rail.
(Only applies to Duplex timing chains)

“A”



“B”



Riveting a Timing Chain.

Note: The following instructions describe the procedure of riveting a Duplex timing chain. The riveting of Simplex timing chains is carried out following the same principle.

1. Connect new timing chain to the old chain by inserting the necessary assembly link “3.4”, “4.4”, “5.4”, “6.2”, “7.2” or “8.2” as shown in Fig. 5; bolt together using screwdriver “11”. Pull in the new timing chain by turning the crankshaft in the direction of engine rotation with the aid of a suitable tool.

Attention: Prevent small parts from falling. Make sure that small parts and dirt are prevented from entering the timing chain case.

Note: Make sure that mounting device **KL-0340-9** (accessory) rests neatly on the timing chain in order to avoid skipping a tooth during assembly.

2. After pulling in the new timing chain, open assembly link “3.4”, “4.4”, “5.4”, “6.2”, “7.2” or “8.2” and remove the old timing chain from the new one.

3. From the rear, insert new chain link into timing chain as far as it goes (as shown in Fig. 6) to link the two ends of the new chain together.

Note: With **Duplex timing chains** it is necessary to additionally insert the centre link plate (as shown in Fig. 6). Then, from the front, insert assembly guide link “3.3”, “4.3” or “5.3” until it rests against the chain link.

4. The following instructions **only apply to Duplex timing chains**. When working on Simplex timing chains, continue with **Point 5**.

4.1 Depending on what assembly insert kit is used **A, C** or **E** (see application table), insert multi thrust piece 1 “9” into riveting base tool “1” as shown in Fig. 7 B.

4.2 Screw centring pin “2” into the appropriate assembly guide rail “3.1”, “4.1” or “5.1”, position it on Duplex timing chain as shown in Fig. 7 A.

Then, place base riveting tool “1” over the assembly guide rail “3.1”, “4.1” or “5.1” on the Duplex timing chain. (Fig. 7 B)

Note: It is also possible to mount the appropriate assembly guide rail “3.1”, “4.1” or “5.1” directly to base riveting tool “1” by means of screw “1.1”, and to place it then onto the timing chain. (not shown).

Fig. 8: Pressing in the centre link plate.
(Only applies to Duplex timing chains)

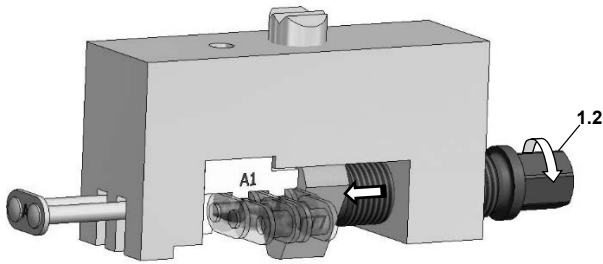

4.3 Press the new assembly link into the centre link plate/timing chain by turning thrust spindle "1.2". Make sure that assembly guide link "3.3", "4.3" or "5.3" cannot fall into the engine. (Fig. 8)

4.4 After turning back thrust spindle "1.2", remove base riveting tool "1" and assembly guide rail "3.1", "4.1" or "5.1" from timing chain.

Fig. 9: Placing the assembly guide rail onto timing chain.

"A"

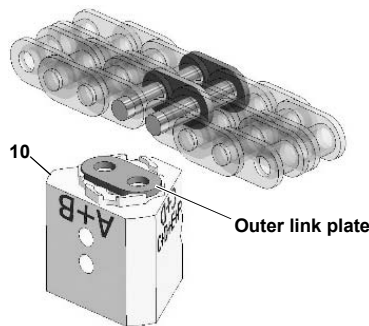

5. Depending on which assembly insert kit is used **A, B, C, D, E or F (see application table)**, insert outer link plate into multi thrust piece 2 "10" as shown in Fig. 9 A.

Note: The link plate is kept in place by a magnet.

"B"

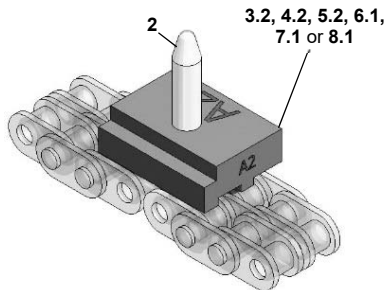

6. Depending on which assembly insert kit is used **A, B, C, D, E or F (see application table)**, insert multi thrust piece 2 "10" into riveting base tool "1" as shown in Fig. 9 C.

"C"

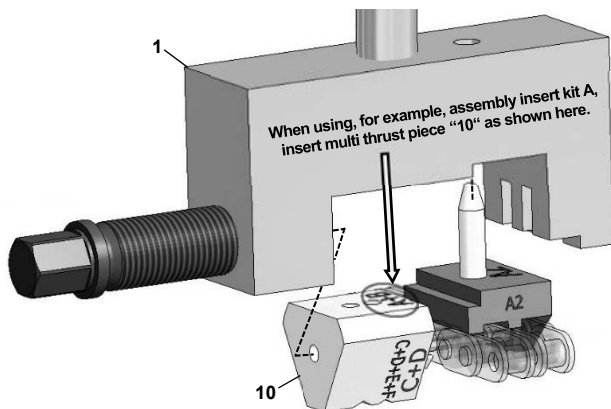

7. Screw centring pin "2" into appropriate guide rail "3.2", "4.2", "5.2", "6.1", "7.1" or "8.1", and place it onto timing chain as shown in Fig. 9 B.

Then, place base riveting tool "1" over guide rail "3.2", "4.2", "5.2", "6.1", "7.1" or "8.1" on timing chain. (Fig. 9 C)

Note: It is also possible to mount the appropriate guide rail "3.2", "4.2", "5.2", "6.1", "7.1" or "8.1" directly to base riveting tool "1" by means of screw "1.1", and to place it then onto the timing chain. (not shown).

Fig. 10: Pressing on the link plate.

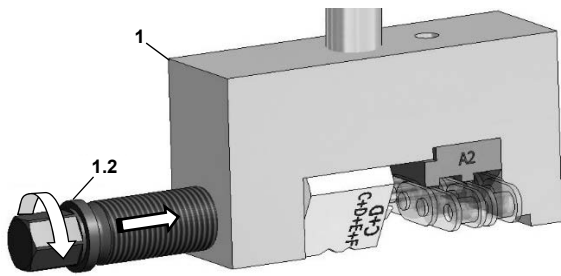
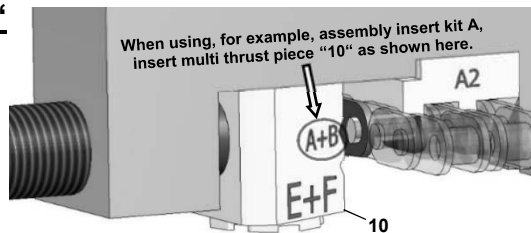

Fig. 11: Riveting the assembly link.

“A”



“B”

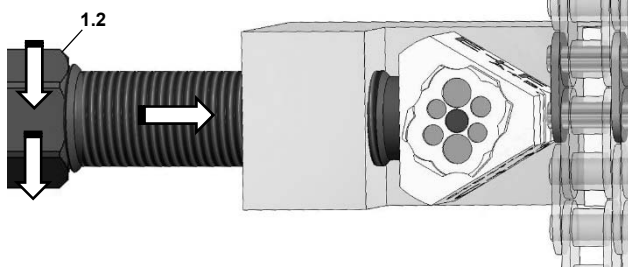
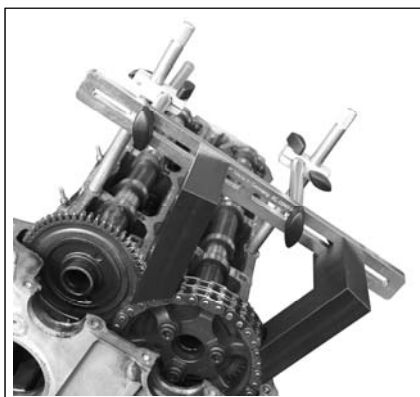
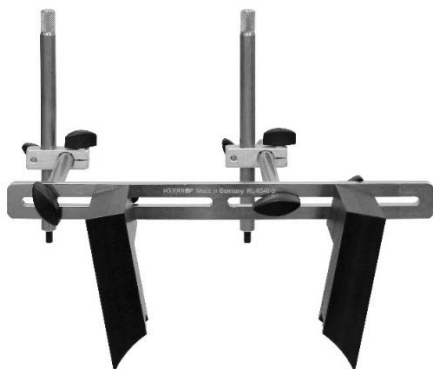

Fig. 12: KL-0340-9 (Accessory)



8. Press the outer link plate onto assembly link by turning thrust spindle “1.2”. Make sure link plate is properly centred. (Fig. 10)

9. Remove base riveting tool “1” from timing chain.

10. To carry out the riveting, insert multi thrust piece 2 “10” into base riveting tool “1” as shown in Fig.11.

Rivet individually each of the two chain pins of the pressed-in assembly link by turning thrust spindle “1.2”.

11. Check to make sure that work was carried out correctly, then remove tool kit from vehicle.

12. Check to make sure that timing is set correctly according to manufacturer's instructions/specifications. Reassemble vehicle.

Accessory:

KL-0340-9 - Universal Mounting Device for Timing Chain

Suitable for the Mercedes and Opel/Vauxhall petrol and Diesel engines both with Simplex and Duplex timing chains.

The special design of the mounting device prevents skipping a tooth during assembly, thus allowing the professional installation of the new timing chain to be performed quickly and without any trouble by just **one mechanic**.

Spare Parts: KL-0340-22 K/KL-0340-23 K

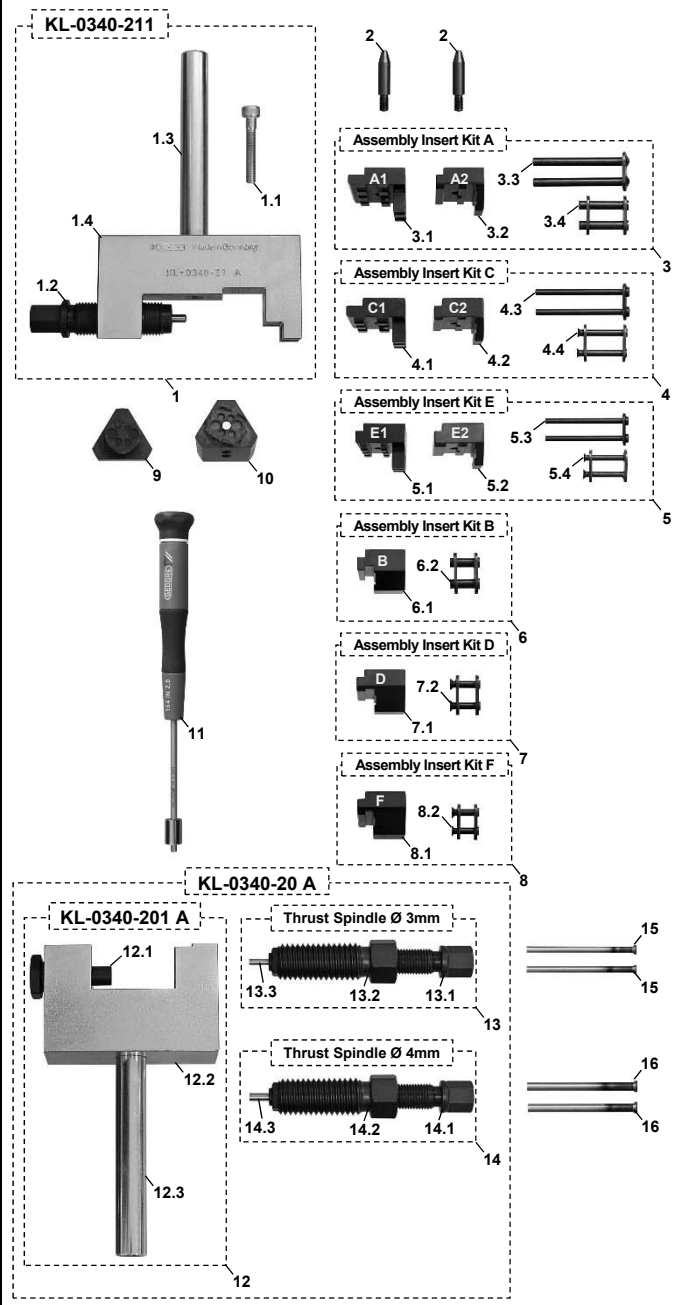

Pos.	Part No.	Description	Qty
3	KL-0340-221	Assembly Insert Kit A	1
<i>composed of:</i>			
3.1	KL-0340-2121	Assembly Guide Rail A1	1
3.2	KL-0340-2131 A	Guide Rail A2	1
3.3	KL-0340-2123	Assembly Guide Link, Ø 4.4mm	1
3.4	KL-0340-2215	Assembly Link, Ø 4.4mm	1
4	KL-0340-223	Assembly Insert Kit C	1
<i>composed of:</i>			
4.1	KL-0340-2231	Assembly Guide Rail C1	1
4.2	KL-0340-2232	Guide Rail C2	1
4.3	KL-0340-2233	Assembly Guide Link, Ø 3.2mm	1
4.4	KL-0340-2235	Assembly Link, Ø 3.2mm	1
5	KL-0340-225	Assembly Insert Kit E	1
<i>composed of:</i>			
5.1	KL-0340-2251	Assembly Guide Rail E1	1
5.2	KL-0340-2252	Guide Rail E2	1
5.3	KL-0340-2253	Assembly Guide Link, Ø 3mm	1
5.4	KL-0340-2255	Assembly Link, Ø 3mm	1

Spare Parts: KL-0340-22 K/KL-0340-23 K

Pos.	Part No.	Description	Qty.	Kit	
				KL-0340-22 K	KL-0340-23 K
-	KL-0340-20 A	Breaker Tool for Timing Chain	1	•	•
1	KL-0340-211	Riveting Tool (base tool)	1	•	•
2	KL-0340-2203	Centring Pin M5	2	•	•
3	KL-0340-221	Assembly Insert Kit A	1	•	•
4	KL-0340-223	Assembly Insert Kit C	1	•	•
5	KL-0340-225	Assembly Insert Kit E	1	•	•
6	KL-0340-222	Assembly Insert Kit B	1	•	•
7	KL-0340-224	Assembly Insert Kit D	1	•	•
8	KL-0340-226	Assembly Insert Kit F	1	•	•
9	KL-0340-2201	Multi Thrust Piece 1	1	•	•
10	KL-0340-2202	Multi Thrust Piece 2	1	•	•
11	KL-0340-2205	Screwdriver	1	•	•
15	KL-0340-205	Clipping Punch, Ø 3mm (2 units)	1	•	•
16	KL-0340-203	Clipping Punch, Ø 4mm (2 units)	1	•	•
-	KL-0340-2090	Plastic Storage Case	1	•	•

Pos.	Part No.	Description	Qty
-	KL-0340-20 A	Breaker Tool for Timing Chain	1
<i>composed of:</i>			
12	KL-0340-201 A	Breaker Tool (base tool)	1
13	KL-0340-204	Thrust Spindle, Ø 3mm	1
14	KL-0340-202	Thrust Spindle, Ø 4mm	1
12	KL-0340-201 A	Breaker Tool (base tool)	1
<i>composed of:</i>			
12.1	KL-0340-2013 A	Centring Sleeve	1
12.2	KL-0340-2011	Base Body	1
12.3	KL-0340-2012	Handle	1
13	KL-0340-204	Thrust Spindle, Ø 3mm	1
<i>composed of:</i>			
13.1	KL-0340-2023	Pressure Screw	1
13.2	KL-0340-2021	Clamping Screw	1
13.3	KL-0340-2031	Clipping Punch, Ø 3mm	1
-	KL-0340-2032	Centring Insert, Ø 3mm	1
-	KL-0340-2035	Clipping Punch Guide, Ø3 mm	1
14	KL-0340-202	Thrust Spindle, Ø 4mm	1
<i>composed of:</i>			
14.1	KL-0340-2023	Pressure Screw	1
14.2	KL-0340-2021	Clamping Screw	1
14.3	KL-0340-2030	Clipping Punch, Ø 4mm	1
-	KL-0340-2022	Centring Insert, Ø 4mm	1
-	KL-0340-2025	Clipping Punch Guide, Ø 4mm	1

Pos.	Part No.	Description	Qty
1	KL-0340-211	Riveting Tool (base tool)	1
<i>composed of:</i>			
1.1	KL-0340-0005	Hexagon Socket Screw, M5x30	1
1.2	KL-0340-2113	Pressure Screw	1
1.3	KL-0340-2012	Handle	1
1.4	KL-0340-2111	Base Body	1

Pos.	Part No.	Description	Qty
6	KL-0340-222	Assembly Insert Kit B	1
<i>composed of:</i>			
6.1	KL-0340-2222	Guide Rail B	1
6.2	KL-0340-2225	Assembly Link, Ø 4.4mm	1

Pos.	Part No.	Description	Qty
7	KL-0340-224	Assembly Insert Kit D	1
<i>composed of:</i>			
7.1	KL-0340-0011 A	Guide Rail D	1
7.2	KL-0340-2245	Assembly Link, Ø 3.2mm	1

Pos.	Part No.	Description	Qty
8	KL-0340-226	Assembly Insert Kit F	1
<i>composed of:</i>			
8.1	KL-0340-2262	Guide Rail F	1
8.2	KL-0340-2265	Assembly Link, Ø 3mm	1